

# Cost estimates of roll-to-roll production of organic light emitting devices for lighting

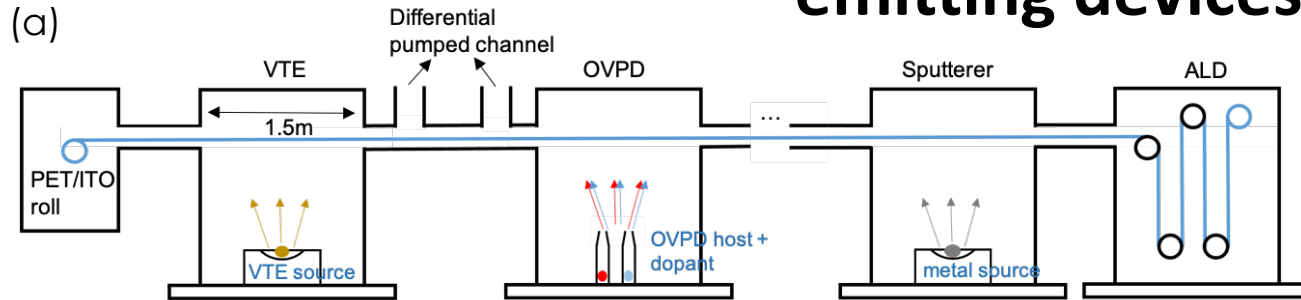

Interconnected R2R production

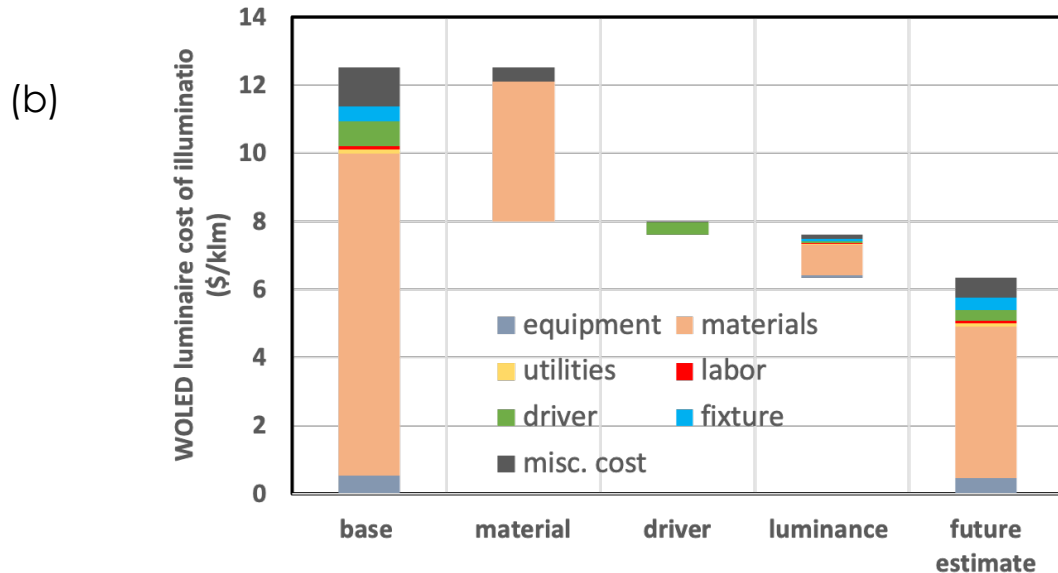

**Figure:** (a) Schematics of the various deposition chambers in an R2R production line that are interconnected through differential pumping. The organic deposition window is 1.5 m-wide. (b) Waterfall diagram showing WOLED light engine cost in \$/klm and the impacts of several near-term cost reduction scenarios based on luminance improvements. WOLED lighting is estimated to cost 6.3 \$/klm.

## Objective

- To understand the tradeoffs in the volume manufacturing of WOLED lighting panels by estimating the cost of white WOLED panel production based on vacuum and vapor phase deposition in a roll-to-roll production line

## Impact

Recent advances in device lifetime and high-speed deposition suggest that mass production of WOLED panels as a lighting source is approaching an inflection point. Assuming a WOLED operating luminance at 10 klm/m<sup>2</sup>, we anticipate a \$12.5 /klm cost of a WOLED light engine that includes the cost of the current driver and packaging. With incremental reduction in material and driver costs, and improved luminance, the cost of WOLED lighting can be reduced to \$6.3 /klm in the near term, potentially positioning WOLEDs for use in numerous premium lighting applications.

## Facilities and Methods Used

- Class 4 of the Cost Engineering Classification system

## Funding

- US Department of Energy Solid State Lighting Program
- Universal Display Corporation

## Contact

- Boning Qu ([boningqu@umich.edu](mailto:boningqu@umich.edu))